

Martin® MHF Series High Frequency External Concrete Form Vibrator



The Martin® MHF Series High Frequency External Form Vibrator solves problems common in the precast industry. These high-frequency, BRUSHLESS electric vibrators will improve material consolidation for exceptional strength and finish.

FEATURES

- BRUSHLESS!
- Can be used portably or permanently
- 115V input with 3 prong plug
- Continuous duty
- 1500 Force lb – 6000 RPM

ACCESSORIES

Part Number	Description
223014	Male Wedge Bracket
V-825006-B	Bolt on Female Wedge Bracket
V-825006-W	Weld-on Female Wedge Bracket

Specify Martin for:

- Cost effective solutions
- Expert technical assistance
- Complete service and support

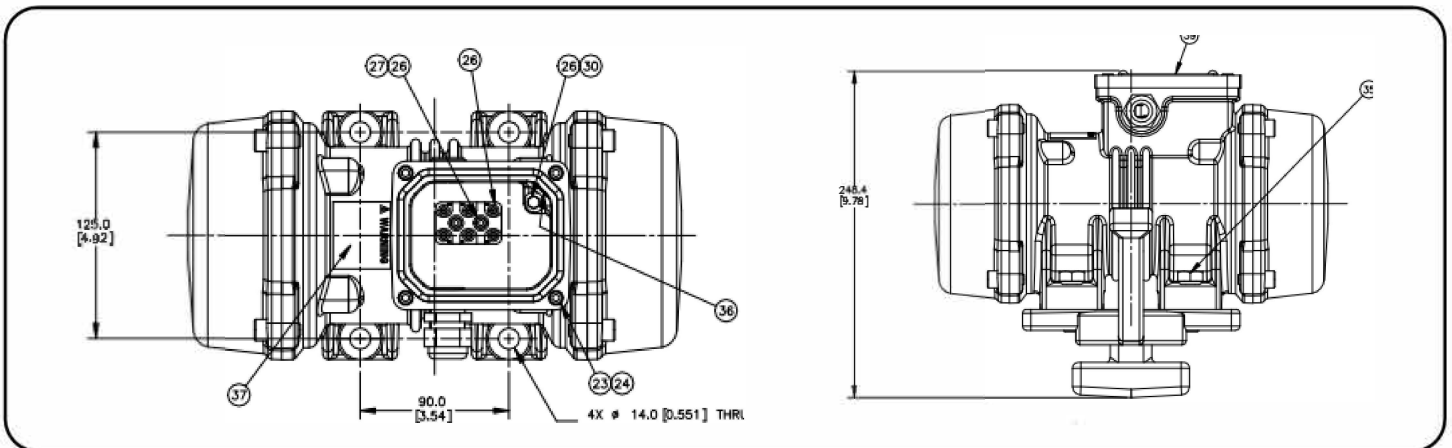

PERFORMANCE DATA

Part Number	Type	Force-Lbs	RPM	Hz	Volts	Amps	PH	kW In	HP	LR Code	Insulation Class	Max Temp	IP Rating
MHF10UC02-X-X	MHF-1500	1500	6000	60-100Hz	230	1.59	3	.21	.25	P	F	40°C	IP66



Distributed By:

ChicagoVibratorProducts
Flow and Compaction
 Division of CVP Group
 800-842-7284 (P)
 866-247-7538 (F)
 Solutions@ChiVib.com
 www.ChicagoVibrator.com

Subject to change without prior notice.
 Quality Management System Certified by DNV - ISO 9001

**COMPANY WITH
 QUALITY SYSTEM
 CERTIFIED BY DNV GL
 = ISO 9001 =**